

Functional modification of poly(vinyl alcohol) by copolymerization: 1. Modification with carboxylic monomers

Tohei Moritani* and Koichi Kajitani

Technical Research Center, Kuraray Company, Sakazu, Kurashiki, Okayama 710, Japan
 (Received 31 May 1996; revised 26 July 1996)

For the purpose of obtaining modified poly(vinyl alcohol-co-vinyl acetate), or partially hydrolysed poly(vinyl alcohol) (PVAL), containing sodium carboxylate groups, $-\text{COONa}$, in polymer chains, ten carboxylic monomers have been investigated for copolymerization with vinyl acetate, and the PVALs obtained by alcoholysis have been compared with each other. Dibasic acidic monomers, itaconic, fumaric and maleic acid, have been found useful for producing modified PVALs showing the functions targeted, reactivity to polyvalent inorganic salts like alum and increasing hydrophilic properties, without any risk of crosslinking. Among these dibasic monomers, itaconic acid has been regarded most practical. By using it, sodium γ , δ -hydroxycarboxylate groups are formed directly in alcoholysis, and PVALs of lower degrees of hydrolysis, even less than 80 mol%, have become possible to be used as water soluble polymers.

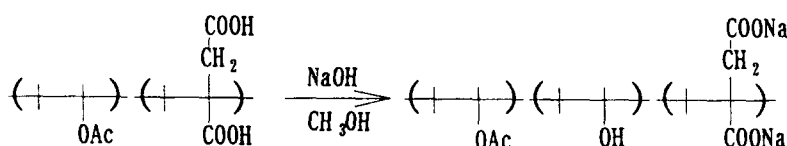

In contrast, maleic anhydride, or monomethyl maleate in methanol solution, cannot be applied to the production of partially hydrolysed PVAL modified thereof due to crosslinking problems; it can be explained by the ring-opening reaction of the δ -lactone formed in alcoholysis.

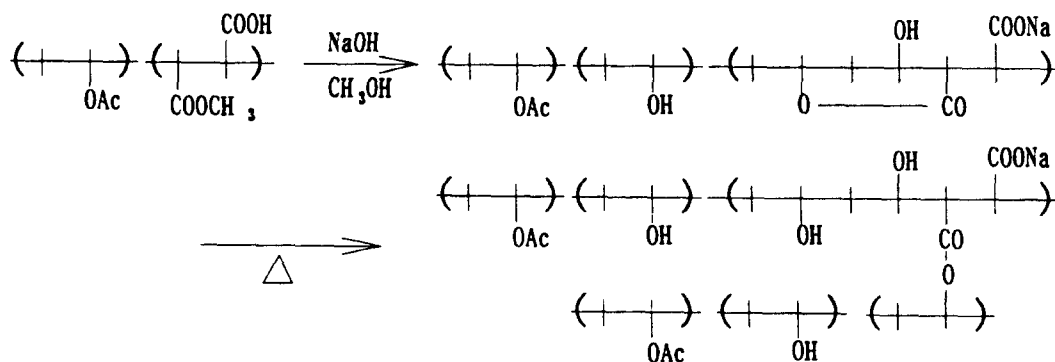

Similar crosslinking has been observed in cases using other dibasic carboxylic ester monomers. Properties and structures in cases using monobasic acidic monomers have also been investigated. © 1997 Elsevier Science Ltd.

(Keywords: poly(vinyl alcohol); copolymerization; carboxylic monomers)

INTRODUCTION

Poly(vinyl alcohol) (PVAL) is a typical synthetic water-soluble polymer produced at the amount of approximately 800 000 t in the world in 1995 and used for wide applications^{1–7} like fibre (vinylon), film, paper sizing, textile sizing, emulsifier, adhesive and others. Tradition-

ally, basic grades of PVAL have been designed from the combinations of degree of polymerization (\bar{P}) and degree of hydrolysis (DH), since PVAL is industrially produced by alcoholysis of poly(vinyl acetate) (PVAC). Major grades of PVALs used as size and emulsifier are those of partially hydrolysed ones, 98 and 88 mol% of DH, or poly(vinyl alcohol-co-vinyl acetate)⁸ to substitute a strict chemical nomenclature although PVAL of further lower DH than about 80 mol% cannot be used due to insolubility in water⁹. The word 'PVAL' used in this paper means both fully and partially hydrolysed

*To whom correspondence should be addressed. Present address: Kuraray Co., Poval Division, 1-12-39, Umeda, Kita-ku, Osaka, 530 Japan

products, as in accordance with the conventional manner.

Functional modification of PVAL, or introducing functional groups into the polymer chain, has been believed to have basic significance with expanding application fields. Many works¹⁰⁻¹² have been reported concerning the modification by polymer reaction for the purpose of introducing carboxylate, sulfonate and amino groups. Copolymerization has been thought to be more convenient in industry and many works have also been reported and reviewed¹³. In the series of the present papers, functional modifications of PVAL by copolymerization with carboxylic, sulfonate, cationic and cross-linkable monomers are reported and discussed from the synthetic, chemical structural and industrial points of view.

Regarding the modification of PVAL with carboxylic monomers by copolymerization followed by alcoholysis, there have been many papers and patents investigating the usage of monobasic acidic monomers like acrylic¹⁴⁻¹⁹ methacrylic²⁰⁻²² and crotonic²³⁻²⁷ acid and their esters as well as monoalkyl maleate²⁸ and maleic anhydride²⁹. No reports on dibasic acidic monomers like itaconic, fumaric and maleic acid for the copolymerization with vinyl acetate (VAc) have been made so far; this must be due to their insolubility to VAc itself. It has been found, however, that these dibasic acidic monomers show 1-3 wt% of solubility to the mixture of VAc and methanol (90/10 w/w) and this is enough for introducing about 20 mol% of carboxyl groups in PVAc by copolymerization because of much higher reactivity of the carboxylic monomers than VAc. The advantages of using the dibasic monomers, itaconic acid in particular, have been shown in this paper.

Due to the fact that the polymer system contains two classes of chemical groups, hydroxyl or its ester and carboxyl or its ester, reactive to each other, much complexity has been experienced. Typical problems must be crosslinking and lactone formation: the latter has already been discussed in literature^{11,15,18,21} but no investigation has been reported for the former. For better understanding of various problems in the modification, ten carboxylic monomers have been investigated and compared with each other. From the investigation on various modified PVALs, discussions have been made for the relationship between properties and chemical structures generated.

Most experimental works written in this paper have been performed long ago³⁰⁻³² but they are believed to still have significance to report now. The novel group of modified PVALs based on the technology have already been used extensively in industry, and their usefulness in applications has been partly reviewed^{33,34}.

EXPERIMENTAL

Carboxylic monomers

Ten carboxylic monomers shown in *Table 1* were used as comonomers in copolymerization with VAc. Most monomer reagents were supplied by Wako Pure Chemical, Ind., Osaka, Japan, except for maleic anhydride and itaconic acid, which were commercially supplied by Mitsubishi Chemical Corp., Tokyo, Japan and Iwata Chemical Co., Iwata, Shizuoka, Japan, respectively. All the reagents had purity over 99% by the analysis of n.m.r.

Copolymerization

Copolymers of VAc and carboxylic monomers were

synthesized using a 5l-glass reactor equipped with a stirrer, a thermometer, a reflux condenser and an apparatus supplying solution continuously. All the copolymerization reactions were carried out in an homogeneous system at boiling temperatures of the system, 60-62°C under the atmosphere of nitrogen gas using methanol and 2,2'-azobis(isobutyronitrile) (AIBN) as solvent and initiator, respectively. In order to obtain copolymers having homogeneous composition of monomer ratio at higher conversions during copolymerization, the 'feeding-comonomer method' was adopted where the supply of the more rapidly consumed comonomer was replenished^{35,36}; the methanol solution of carboxylic monomer was supplied continuously and the supply speed was regulated on the basis of the solid content analysed occasionally and the balance amount was calculated using the monomer reactivity ratios, r_1 and r_2 . The monomer reactivity ratios used are shown in *Table 1*.

The monomer reactivity ratios r_1/r_2 for the copolymerization of itaconic acid and VAc and those for dimethyl itaconate and VAc have been determined in this work as 20.4/0.029 and 8/0.0113, respectively using the samples copolymerized at lower degrees of conversion of VAc under 5%³⁷. The values of r_1/r_2 for dimethyl itaconate were assumed for the copolymerization using monomethyl itaconate. Reported values were used for methyl methacrylate³⁸, methacrylic acid³⁹, monomethyl maleate⁴⁰. In cases of maleic acid and fumaric acid, values reported for monomethyl maleate and dimethyl fumarate⁴¹ were applied, respectively. No information was available for the case of vinyl acetic acid.

Feed amounts of reagents are described as weight part in *Table 1* for convenience of calculation. The copolymerization was finished by cooling the reactor and introducing air into it, and the residual VAc was distilled out by introducing methanol gas into the reactor under reduced pressure. The small amount of the modified PVAc was purified by precipitation of the methanol solution in water twice and analysed using ¹H n.m.r. Typical examples of copolymerization results are shown in *Table 1*.

Alcoholysis

Modified PVALs were obtained by alcoholysis of modified PVAc; the methanol solution of sodium hydroxide was added to the methanol solution of modified PVAc with stirring at 40°C. The addition of a small amount of sodium hydroxide, 0.004-0.2 mole ratio to VAc units, was enough for alcoholysis for usual non-modified PVAc (Samples 1 and 2 in *Table 1*) and for the PVAc modified with methyl methacrylate (Sample 3), dimethyl maleate (Samples 9 and 10) or dimethyl itaconate (Samples 11 and 12). On the other hand, more sodium hydroxide was used in the cases of the modified PVAc containing the acidic group, -COOH, where alcoholysis occurred by sodium hydroxide exceeding the amount of neutralization. Modified PVALs having various DH were obtained by controlling the amount of sodium hydroxide. Gelatinous PVAL generated by alcoholysis was ground, heated in the mixture of methanol, methyl acetate and small amount of water for removing residual sodium hydroxide, and dried. Some samples for analysis were washed in a Soxhlet's extractor with methanol and dried. Analytical results for the typical examples of modified PVALs are also shown in *Table 1*.

Table 1 Synthesis of poly(vinyl alcohols) modified with carboxylic monomers by copolymerization and alcoholysis

No.	Carboxylic monomer ^a (MW) [r_1/r_2]	Feed in copolymerization (part)				Reaction time min	Extent of conversion of VAc %	Modified PVAC Δ^b mol%	\bar{P}_n^c	Degree of hydrolysis mol%	Modified PVAL	
		VAc Initial/Additional	Carboxylic monomer Initial/Additional	Methanol Initial/Additional	AIBN						Viscosity (4%, 20°C) cP	Reactivity to alum
1	None	1000	0/0	302/0	0.40	237	68.0	0	1755	99.0	28.3	No
2										71.5	Phase separation	-
3	Methyl methacrylate (100.1) [26.0/0.03]	1000	0.3/3.0	125/10	0.75	90	34	2.0		99.0	25.7	No
4	Methacrylic acid (86.1) [20/0.01]	1000	1.8/30.0	125/10	0.15	185	41	6.0		89.2	27.4	Weak
5	Vinyl acetic acid (86.1) []	1000	4.0/2.3	250/0	1.0	68	10.2	5.8		98.2	31.4	Weak
6	(Maleic anhydride)									98.5	28.0	Gel
7	Monomethyl maleate (113.1) [0.0/0.09]	1000	2.1/15	282/15	1.4	290	70.4	2.0		92.3	Gel	-
8										86.5	Gel	-
9	Dimethyl maleate (144.1) [0.028/0.12]	1000	6.4/17	252/0	1.5	90	37.0	3.3		98.3	25.3	Gel
10										90.8	Gel	-
11	Dimethyl itaconate (158.1) [8/0.0113]	1000	0.9/40	429/40	2.0	300	54.3	3.9		99.5	24.0	Gel
12										95.1	Gel	-
13	Monomethyl itaconate (144.1) [8/0.0113]	1000	0.6/33	250/100	1.0	380	64.9	3.0		98.8	30.1	Gel
14										92.1	Gel	-
15	Maleic acid (116.1) [0.0/0.09]	1000	5.2/18	177/54	0.7	180	48.5	3.0	1892	91.2	35.5	Gel
16										75.1	24.6	Gel
17										96.9	41.5 ^d	Gel
18	Fumaric acid (116.1) [0.32/0.031]	1000	0.9/17	316/17	1.0	270	64.1	2.0		88.8	35.2 ^d	Gel
19										77.7	28.3 ^d	Gel
20		1000	2.4/32	177/95	1.0	280	33.5	5.0	1340	94.1	20.5	Gel
21										46.2	23.8	Gel
22	Itaconic acid (130.1) [20.4, 0.029]	1000	0.8/20.0	235/29	1.4	195	65.2	2.0	1659	97.0	27.3	Gel
23										77.2	19.5	Gel
24										66.6	26.0	Gel
25		1000	0.11/2.7	1500/8.1	8.0	190	73.3	0.25	561	98.0	5.0	Weak
26										70.6	6.2	Weak

^a MW: Molecular weight. r_1/r_2 : Monomer 1 = carboxylic monomer, Monomer 2 = VAc

^b Mole fraction of carboxyl monomer units

^c Viscosity-average degree of polymerization

^d Opaque or milky

Structural analysis

^1H n.m.r. spectra were obtained with Varian EM-390 at 90 MHz. As solvents and internal standard reagents, CDCl_3 and hexamethyldisiloxane were used for modified PVACs, while D_2O and sodium trimethylsilylpropionate- d_6 were used for modified PVALs. The spectra were used for the determination of the mole fraction of carboxylic monomer units in modified PVACs and of DH of modified PVALs. The mole fraction of carboxyl monomer units and DH in modified PVALs were also determined by using conductometric titration and neutralization titration, respectively. I.r. spectra were obtained using an IR-270 spectrometer from Shimadzu Corp. for the film samples of $10\ \mu\text{m}$ thick: the film samples prepared by drying aqueous solutions. The spectra were used for the analyses of carboxylates and lactones.

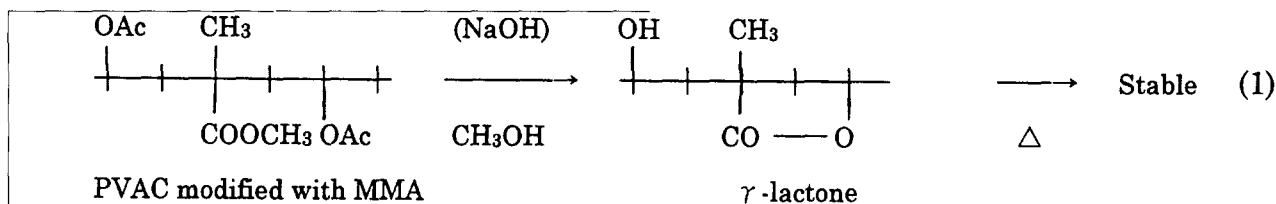

Degree of polymerization

Limiting viscosity number, $[\eta]$, was measured at 30°C in water for the non-modified PVAL and in sodium chloride solution (1 N) for carboxylic-modified PVALs. Viscosity-average degree of polymerization was calculated by using the equation presented by Sakurada, $P_v = ([\eta] \times 10^4 / 8.33)^{1.61}$.

Viscosity of aqueous solution

Viscosity of PVAL aqueous solution (4 wt%, 20°C) was measured using a Brookfield viscometer for samples giving clear solution as well as for samples showing opaque appearance. No viscosity data are shown for the samples generating insoluble gel and for the samples showing phase separation.

Reactivity to polyvalent salts

Qualitative evaluation was made for the reactivity of the modified PVALs to various polyvalent salts in mixing experiment by adding aqueous solutions of salts (1–10%) to aqueous solutions of PVALs (10%) with stirring. Gel formation was regarded as a measure of reactivity.

Applications

(a) *Paper sizing*: Paper, unprocessed with any polymer sizing like starch, was impregnated or sized with about 6 wt% aqueous PVAL solutions using a size-press machine equipped with rollers. Resistance to air permeability of the paper processed was measured using OKEN-type air permeability tester.

(b) *Textile sizing*: As a model evaluation of sizing poly(ethylene terephthalate) fibre, the adhesive strength of PVALs coated on poly(ethylene terephthalate) film was measured.

RESULTS

Modification with various carboxylic monomers, resulting structures in modified PVALs and their properties

Non-modified PVAL. The highly hydrolysed PVAL (Sample 1 in Table 1) gives clear aqueous solution while

the PVAL lower hydrolysed, 71.5 mol% of DH (Sample 2), generates aqueous dispersion or phase separation on standing although the PVAL is soluble perfectly to dimethyl sulfoxide (DMSO). Insolubility in water is attributable to increasing hydrophobic property due to lower DH.

Modification with methyl methacrylate (MMA). Alcoholysis of the PVAC modified with 2.0 mol% of MMA units yields polymer showing good solubility to water (Sample 3), and the solid sample heat-treated at 100°C also shows perfect solubility. The sample, however, shows no reactivity to alum. This can be explained by the fact that MMA units are hydrolysed in alcoholysis but convert to inactive γ -lactone [equation (1)], as already reported in literature^{15,18,21}.

The structural analysis using i.r. spectra is shown in Figure 1. Key i.r. absorption signals observed in the original sample (A) are those of 1580 and $1740\ \text{cm}^{-1}$, which can be assigned to $\text{C}=\text{O}$ stretching of $-\text{COONa}$ (sodium carboxylate units in the chain and sodium acetate as a by-product formed in alcoholysis) and

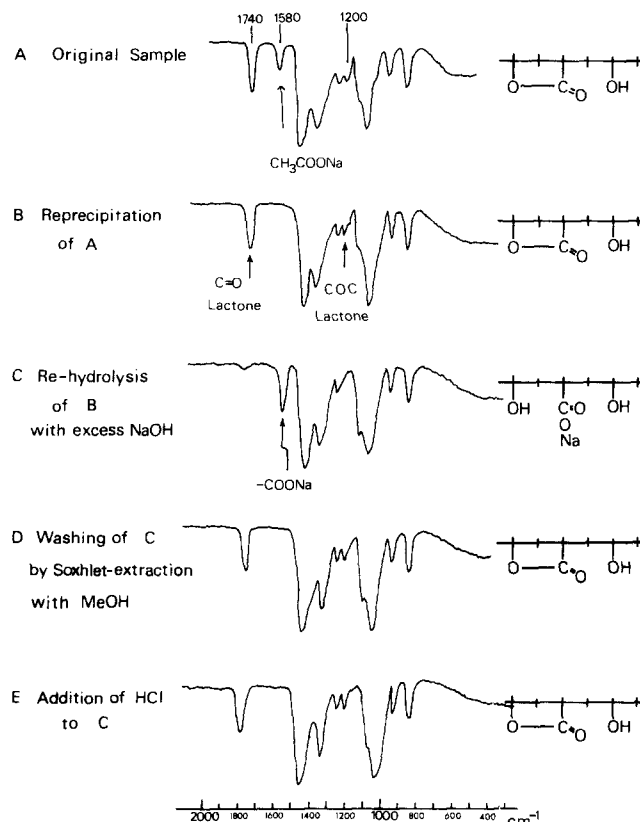
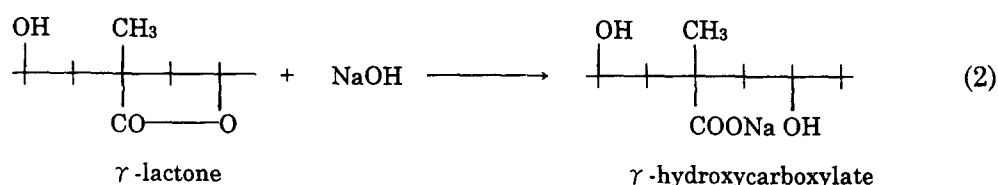
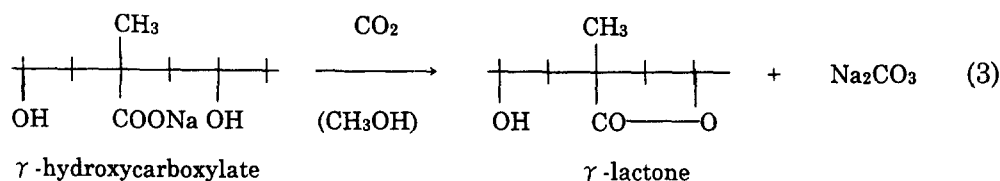

Figure 1 I.r. spectra of the modified PVAL obtained from the copolymerization of vinyl acetate and methyl methacrylate followed by alcoholysis. The original PVAL sample contains 2.0 mol% of lactones in the chain from methyl methacrylate. Structural changes of the groups under various treatments are shown

esters (lactone and residual VAc and MMA units), respectively. N.m.r. analysis showed 0.8 mol% of residual VAc units and no signal for residual methyl groups from MMA. In the sample (B) obtained from reprecipitation of the aqueous solution of sample (A) into methanol, the former absorption observed in (A) disappears and the intensity of the latter absorption does not change. Hence the absorption observed in the original sample (A) at 1580 cm^{-1} can be assigned to the signal from sodium acetate. Therefore all the carboxylic methyl ester groups in the modified PVAC are regarded to have converted to lactone form in alcoholysis. The lactone form can convert to sodium carboxylate form by mixing the PVAL with sodium hydroxide in aqueous solution, as shown in the spectrum (C).



However, washing of the solid sample containing sodium carboxylate units by a Soxhlet's extractor with methanol, a usual method for purification of PVAL sample, results in converting all the sodium carboxylate to γ -lactone, stable five-membered ring, again (D). The extract dissolved in methanol was analysed as sodium carbonate. The following reaction can be assumed during the washing procedure:



Addition of hydrochloric acid to the aqueous solution of (C) also yields the same product (E), as is known in literature¹⁴⁻¹⁶.

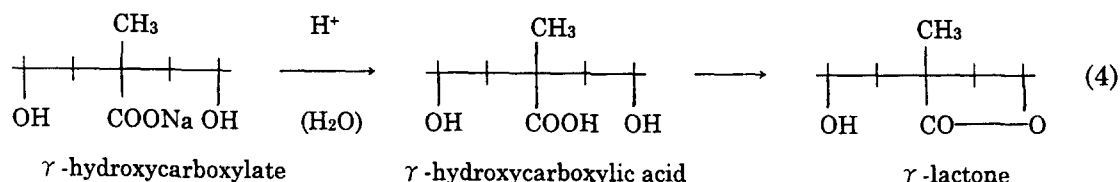

Modification with methacrylic acid (MAA). Alcoholysis of the PVAC modified with 6.0 mol% of MAA units also yields polymer showing good solubility to water (Sample 4), and showing reactivity to alum, but the reactivity is relatively weak. Unlike the modification with MMA, PVAL containing sodium carboxylate units, or γ -hydroxycarboxylate, is formed in alcoholysis directly as follows:

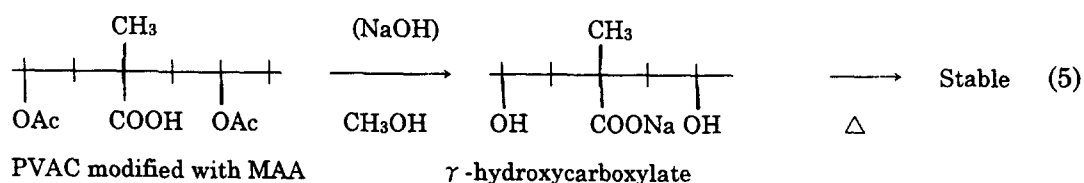

Conversion of all the sodium carboxylate to γ -lactone was also observed by washing the solid sample by a Soxhlet's extractor with methanol, shown by equation (3).

Modification with vinylacetic acid. Copolymerization of VAc and vinylacetic acid, $\text{CH}_2 = \text{CHCH}_2\text{COOH}$, and alcoholysis (Sample 5) have been carried out for investigating the relationship between structure and properties depending on the carboxylic monomers because it provides modified PVAL containing δ -hydroxycarboxylate as follows:

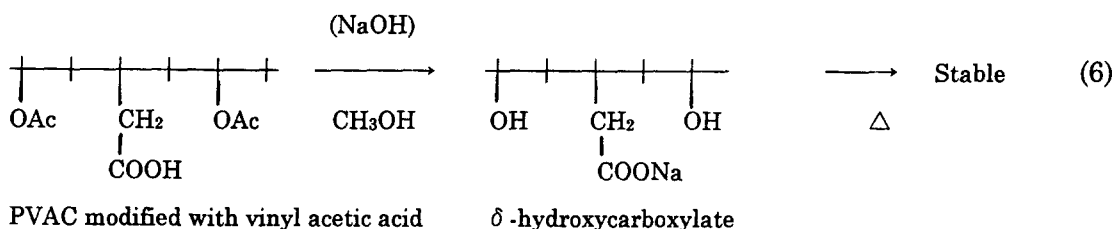

I.r. spectrum of the product after alcoholysis and drying shows the direct generation of sodium carboxylate units. Clear difference from the modification with MAA has been found for the washing of the solid sample by a Soxhlet's extractor with methanol. Both i.r. spectra for the original sample and the sample after washing for 24h have shown the same and both samples contain sodium carboxylate groups and do not show any generation of lactone.

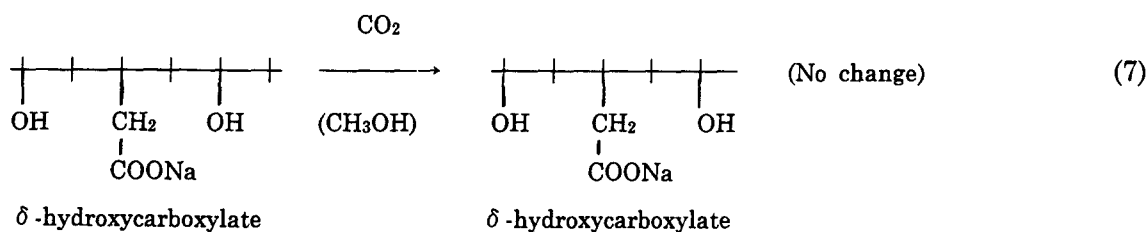

This means a significant fact that δ -hydroxycarboxylate has resistance to conversion into lactone form by the action of weak acid like carbon dioxide, in contrast to the γ -hydroxycarboxylate in the PVALs modified with MAA. This difference in conversion to lactone between γ - and δ -hydroxycarboxylates can be explained by the reaction rates of conversion of γ - and δ -hydroxycarboxylic acid to corresponding lactones in model compounds⁴²: the rate of forming a five-membered ring, γ -form, is about a hundred times faster than that of forming a six-membered ring, δ -form.

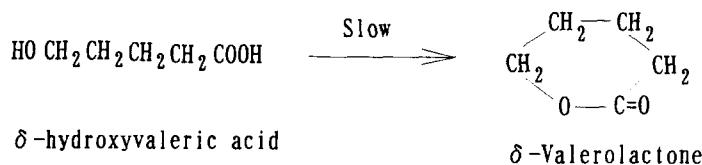

Modification with maleic anhydride (MAn), dimethyl maleate (DMM), dimethyl itaconate (DMI) and monomethyl itaconate (MMI). The copolymerization of VAc and MAn in methanol solution produces the copolymer of VAc and monomethyl maleate (MMM)²⁹; this was confirmed using n.m.r. analysis.

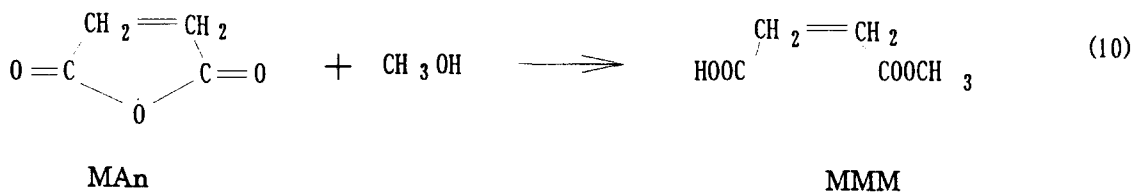

Alcoholysis of the PVAC modified with 2.0 mol% of MMM units yields polymer showing good solubility and high reactivity to alum (Sample 6) in the case of the samples having high DH.

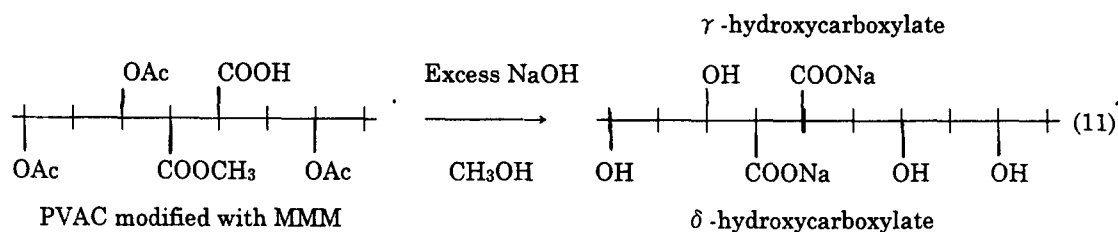

On the other hand, the samples having partial DH (Samples 7 and 8) dried at 90°C are insoluble or show only swelling in boiling water and in hot DMSO. From the fact that the material dried at room temperature under reduced pressure after alcoholysis is soluble, the insolubilization of the samples is regarded to occur during drying at higher temperatures. In the alcoholysis of the PVAC modified with MMM, carboxylic methyl ester units are believed to make δ -lactones, and the δ -lactones subsequently open the unstable six-membered ring to make intermolecular ester with hydroxyl group or to make crosslinking, as shown in equation (12).

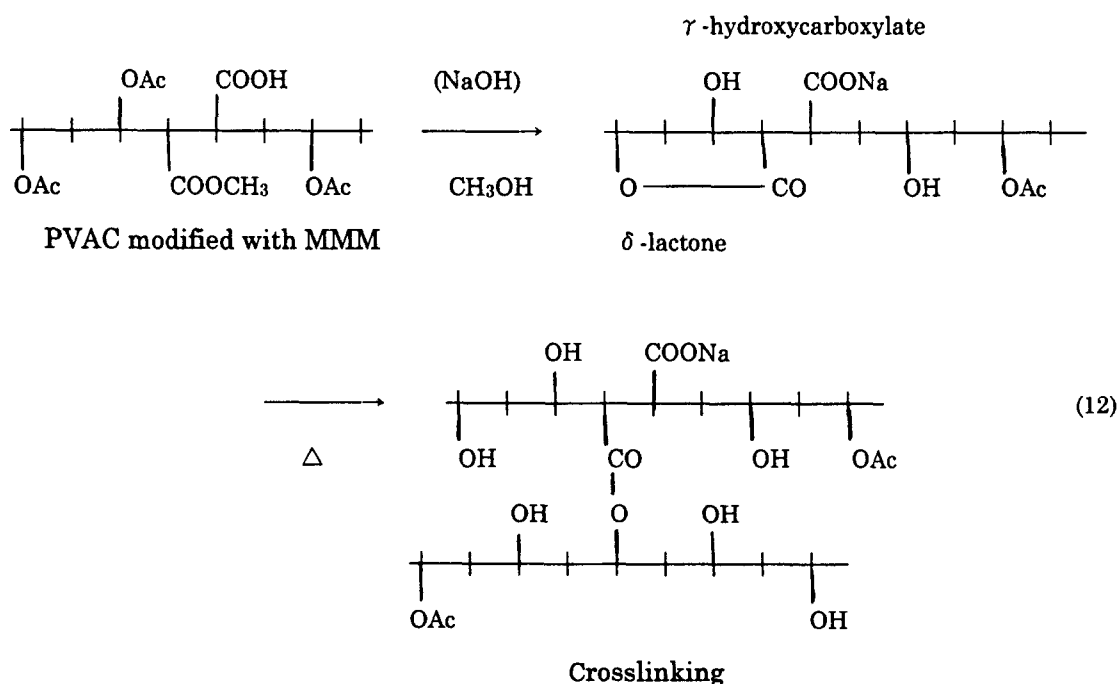

This mechanism can be supported by the reactivity of the model compound shown in equations (13) and (14): γ -lactone is stable on heating while δ -lactone easily makes the ring open and polymerizes⁴³.

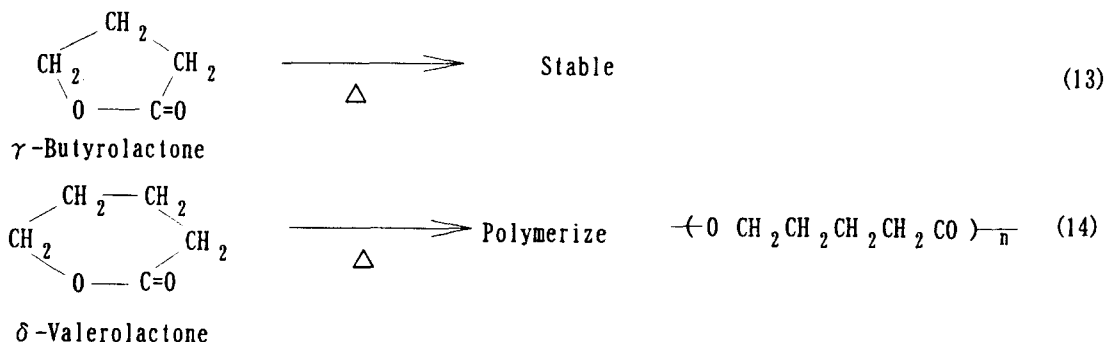

The same situation, soluble for highly hydrolysed PVALs whereas insoluble for partially hydrolysed ones, is shown in the cases of the modification with DMM, DMI and MMI (Samples 9–14).

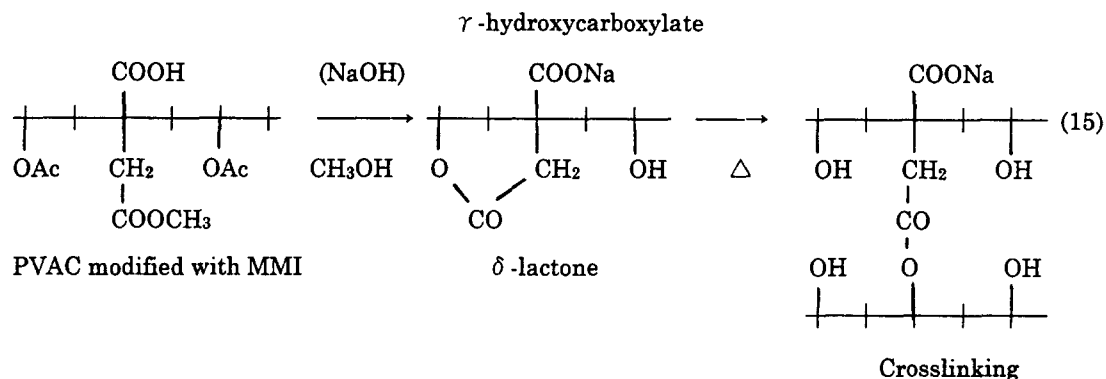

Modification with itaconic acid (IA), fumaric acid (FuA) and maleic acid (MaA). These three dibasic-acidic monomers are insoluble to VAc but show low solubility up to about 3 wt% for IA and MaA and about 1 wt% for FuA in the mixture of VAc and methanol (90/10 wt/wt), a typical composition of polymerization in industry. Such low solubility has been found enough to make modified PVACs containing the dibasic-acidic monomer units up to about 20 mol% due to much higher reactivity of the acidic monomers than that of VAc.

Using these monomers, typically using IA, it has been found that the modified PVALs show good solubility to water not only for highly hydrolysed ones but also partially hydrolysed ones even when dried at higher temperatures (Samples 15–26): any problem of crosslinking does not occur in the production process. Furthermore it has also been found that PVALs having much lower DH, down to 46.2 mol% (Sample 21) for example shown in Table 1, provide clear aqueous solution not having any 'clouding point temperature'. The improvement of solubility for the modified PVALs of lower DH is believed due to increasing hydrophilic property of sodium carboxylate units. Sample 26 shows modification with as small amount of sodium itaconate units (0.25 mol%) is effective that the modified PVAL of lower DH, 70.6 mol%, shows good solubility to water.

When using dibasic comonomers like IA, FuA or MaA in copolymerization, the modified PVALs are

believed to contain sodium γ,δ -hydroxycarboxylate units directly in alcoholysis independent of DH as follows:

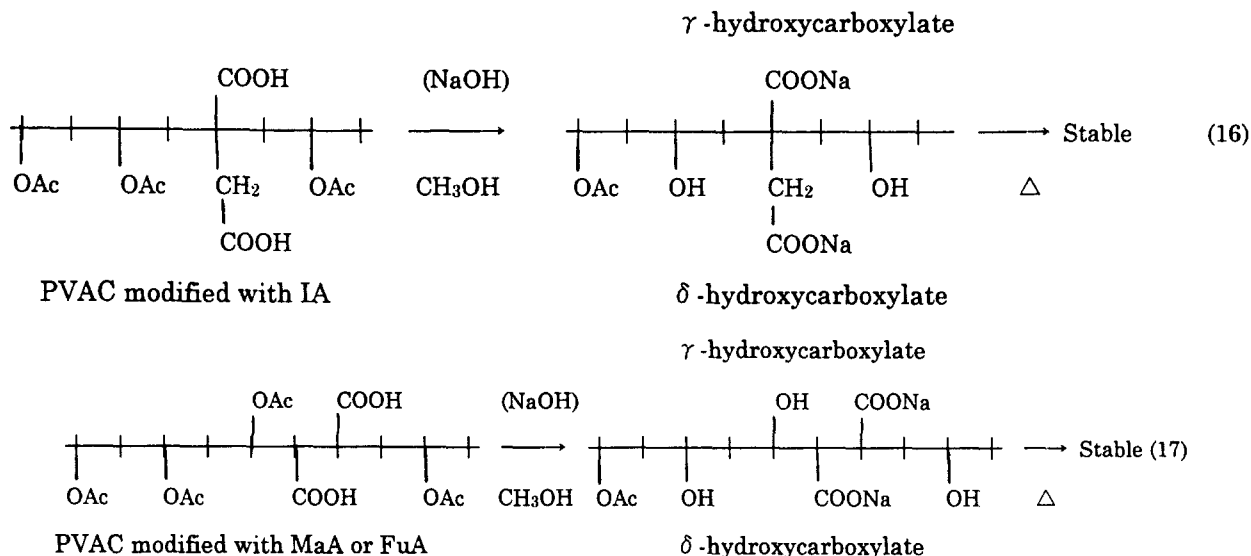

The δ -hydroxycarboxylate in the cases of PVALs modified with MaA and FuA can also be described as β -hydroxycarboxylate, but the former description is adopted in this paper because of the significance in relation to lactone formation.

Figure 2 shows the change of i.r. absorbance of carboxylate, lactone and ester groups in the PVAL modified with 2.2 mol% of sodium itaconate units in relation to the time of washing the solid PVAL by a Soxhlet's extractor with methanol. The original modified PVAL sample was synthesized by usual processes; copolymerization, extraction of residual VAc with methanol, alcoholysis using sodium hydroxide, grinding and drying. The sample contains residual VAc units of 1.2 mol% in the polymer chain and a small amount of sodium acetate as a by-product: the latter gives absorption at 1580 cm^{-1} which overlaps that of $-\text{COONa}$ included in the polymer, while the former at 1740 cm^{-1}

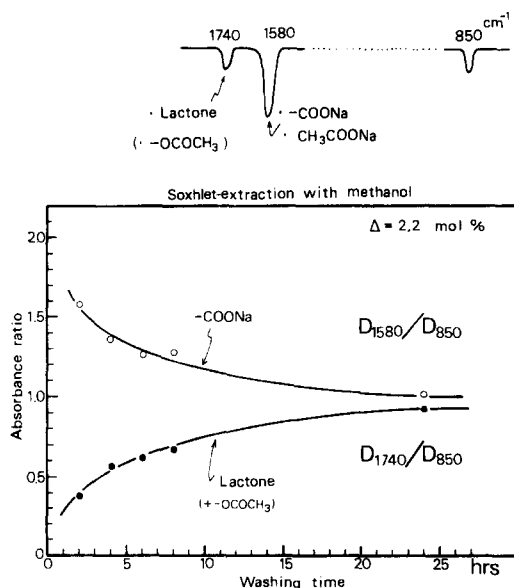
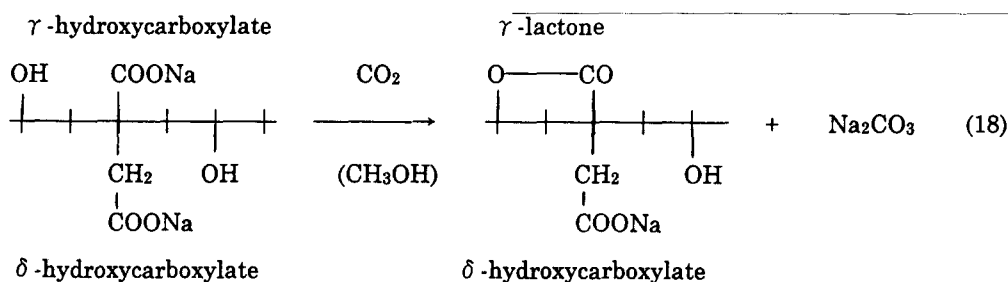

Figure 2 The change of absorbance strength in i.r. spectra for two absorption signals observed in the PVAL modified with 2.2 mol% of sodium itaconate units during washing by a Soxhlet's extractor with methanol

overlaps that of lactone. Both absorption intensities are measured as the area ratios to the absorption intensity at 850 cm^{-1} as an internal standard⁴⁴. In the original sample, the signal at 1580 cm^{-1} shows the strongest intensity in this experiment while small signal is observed at 1740 cm^{-1} ; the latter can be assigned to residual VAc units. With washing time, the intensity of the absorption at 1580 cm^{-1} decreases while that at 1740 cm^{-1} increases and the absorption ratios become almost equivalent after 24 h. The modified PVAL washed after 24 h and dried at 100°C shows good solubility to water. From this experiment, the following two conclusions can be obtained for the structure of the PVAL modified with IA:

1. In the original sample, all the modified groups from IA are regarded to exist essentially as the form of sodium carboxylate, or sodium γ, δ -hydroxycarboxylate.
2. The following reaction occurs during the washing procedure in the presence of carbon dioxide:



The conclusions are consistent with similar experimental results for PVALs modified with MAA or with vinyl acetic acid, discussed before.

Concerning the modification with FuA, some anomaly has been observed: the aqueous solution of the PVAL modified thereof shows opaque or milky appearance, as shown in Table 1 for the PVAL containing 2 mol% of sodium fumarate units. This is in contrast to the PVALs modified with IA or MaA, where transparent aqueous solutions are obtained. Besides the PVAL shown in Table 1, PVALs containing 1, 3, 5 and 20 mol% of sodium fumarate units were synthesized and investigated regarding the phenomenon. The results are summarized as follows: (1) All the PVALs modified with FuA provide opaque aqueous solutions at the concentration of 10 wt%. (2) The degree of opaqueness increases with increasing the mole fraction of sodium fumarate units and with increasing DH. (3) Samples purified by reprecipitation, washing by a Soxhlet's extractor with methanol and dialysis during twenty days show no change in this phenomenon. (4) Addition of sodium hydroxide in aqueous solution shows no change. (5) It is observed that the opaqueness is formed by fluid drops of 10–100 μm in diameter. The reason for the anomalous phenomenon peculiar to the PVALs modified with FuA has not yet been clarified.

The problem concerning MaA is commercial availability due to the problem of isomerization to fumaric acid^{45,46}. Maleic anhydride, MAN, is the product supplied commercially but it causes the problem of crosslinking in the modification of PVAL, as explained before.

Thus, it can be concluded that IA is the most convenient carboxylic monomer for the production of

partially hydrolysed PVALs containing dibasic sodium carboxylate units.

Reactivity to polyvalent inorganic salts. Reactivity to polyvalent inorganic salts is believed to be one of the typical properties of carboxylate groups and to invest PVAL an effective function for practical applications such as the paper industry where alum is extensively used as an additive. In Table 1, qualitative observation on the reactivity to alum in aqueous solution for various modified PVALs is shown. Clear gelation is observed for the PVAL modified with dibasic acidic monomers while little change is observed for the mixture with non-modified PVAL and the PVAL modified with MMA. The PVALs modified with MAA or vinyl acetic acid show weak reactivity or increasing viscosity. Table 2 shows the experimental results of the reactivity of the PVALs modified with IA (IA-PVAL) to various polyvalent inorganic salts in aqueous solution. IA-PVAL generates gel

in contact with various salts while non-modified PVAL does not.

DISCUSSION

Subjects in PVAL modified with carboxylic monomers

As discussed above, some complexity has been felt in producing and treating the PVALs modified with carboxylic monomers: this complexity must come from the fact that the polymer chain contains the two chemical groups reactive to each other, hydroxyl and carboxylic. From the practical point of view, crosslinking problem in production and processing, usability of soluble PVAL having much lower DH, chemical activity of modified groups and the best selection of carboxylic monomer for modification must be main subjects of interest. The discussions related to these subjects are summarized below.

Crosslinking in production. From the experimental results described above, this problem can be summarized as follows:

(a) *Mechanism.* As shown in equations (12) and (15), crosslinking is believed to be formed by the intermolecular ester linkages as the result of ring-opening reaction of δ -lactones formed beforehand in alcoholysis. The conversion of δ -lactone to intermolecular ester linkage is caused in drying at higher temperatures. The reaction of δ -valerolactone shown in equation (14) supports the mechanism. Avoiding the generation of δ -lactone, 'ring-leader' causing the risk of crosslinking problem, is believed to be the first key for producing partially hydrolysed PVALs modified with carboxylic monomers as water-soluble polymers.

(b) *Monomers.* Maleic anhydride, or monomethyl maleate in methanol solution, and dibasic acidic ester monomers inevitably make crosslinking for partially hydrolysed PVALs modified thereof, already shown above.

In contrast, all the acidic monomers, monobasic and dibasic, cannot have any risk of generating gel or crosslinking in usual production process because alcoholysis occurs after the formation of sodium carboxylate and makes no chance of generating δ -lactones.

(c) *Degree of hydrolysis.* There are no crosslinking problems for fully hydrolysed PVALs modified even with maleic anhydride under the conditions of alcoholysis using excess sodium hydroxide; this is due to the conversion of δ -lactone to δ -sodium hydroxycarboxylate in the procedure.

Usage of novel PVALs having much lower degrees of hydrolysis. There have been four typical main grades used in traditional PVAL industry, as shown in Figure 3, as combinations of degree of polymerization (\bar{P}), higher \bar{P} and lower \bar{P} , and the degree of hydrolysis (DH), higher DH (H) and medium DH (M). By introducing sodium carboxylate groups into PVAL using IA in particular, a novel group of PVALs having much lower DH, denoted as 'L' in Figure 3, has been able to be used as water soluble polymer. These novel PVALs have been found useful in industry as shown later.

Functional activities of modified groups in relation to their structures. Typical 'functional activities' of the modified groups in carboxylic-modified PVALs are attributable to two properties: increasing hydrophilic property and reaction with polyvalent inorganic salts like alum. The functional activities are observed to increase with increasing the mole fraction of the sodium carboxylate group. Dibasic monomer units showed stronger reactivity than monobasic ones to polyvalent inorganic salts presumably due to 'chelating effects', although the present observation was rather qualitative and quantitative experiments are necessary for more precise discussion.

γ -Lactone structure is essentially inactive or insignificant in functional activity. Such inactive lactone structure can be formed in case of using carboxylic ester monomers as comonomers directly in alcoholysis as shown above. γ -Lactone can also be formed by the conversion from γ -hydroxycarboxylate by the action of acid. In contrast, δ -hydroxycarboxylate has resistance to the conversion to inactive lactone form, and hence it can be expected to keep more stable functional activities.

'Carboxylic group' in modified PVALs. Now it should be pointed out again that any PVALs modified with usual carboxylic monomers are believed not to contain any 'carboxylic group', $-\text{COOH}$, in usual conditions but to contain other structures such as carboxylates like $-\text{COONa}$, inactive and stable γ -lactone, unstable δ -lactone, residual esters and ester linkages. In this meaning, the following chemical expression shown sometimes in literature as 'PVAL modified with carboxylic groups' is regarded as unsuitable or misleading:

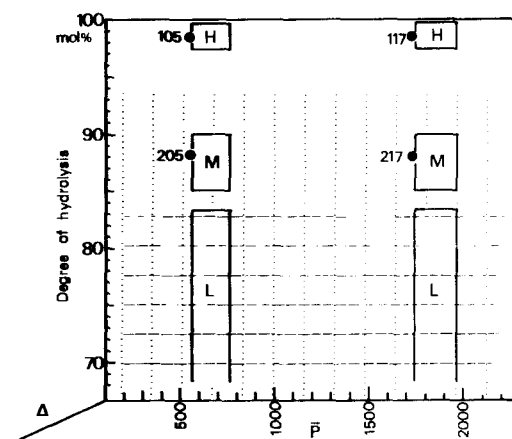
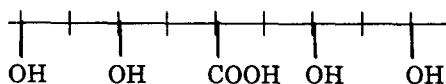

Figure 3 Typical grades of poly(vinyl alcohol) as expressed by degree of polymerization (\bar{P}), degree of hydrolysis (DH) and the mole fraction of modified groups (Δ). In addition to PVALs of higher degree of hydrolysis (H) and medium degree of hydrolysis (M), PVALs of much lower hydrolysis (L) can be used as a new series of water soluble polymers in the poly(vinyl alcohol)s modified with sodium itaconate units

This structure can be formed in aqueous solution at lower pH but should be converted to γ -lactone, as observed experimentally for the PVALs modified with MMA or MAA. Thus, from the practical point of view, it seems a reasonable expression or nomenclature to use 'PVAL containing carboxylate groups', or 'PVAL modified with carboxylic monomers'.

Advantages of dibasic carboxylic monomers. The advantages of using the dibasic acidic monomers like IA in the modification of PVAL can be summarized below.

1. To generate γ, δ -hydroxycarboxylates directly in alcoholysis: the dibasic carboxylates show high hydrophilic property as well as strong reactivity to inorganic salts presumably due to chelating effects.
2. No crosslinking problem occurs in production.
3. A novel group of water soluble PVALs having much lower DH can be produced.
4. The δ -hydroxycarboxylate included is so stable in comparison with γ -hydroxycarboxylate as to have resistance to conversion to inactive lactone by the action of weak acid.

Problems in dibasic monomers. Among the dibasic acidic monomers for the above purposes, IA is now regarded as most useful because MaA and FuA have respective problems as discussed before. The clarification of the anomalous behaviour observed in PVAL modified with FuA can be the next subject for carboxylic modification of PVAL.

Significance in industry

Paper sizing. Figure 4 shows the resistance to air permeability measured for sized paper with PVALs. IA-PVAL, partially hydrolysed products classified as 'M' in particular, shows much higher resistance, or barrier. These high barrier characteristics are believed

(Unsuitable expression) (19)

Table 2 Reactivity of the PVAL modified with sodium itaconate (IA-PVAL) and non-modified PVAL with various inorganic salts in aqueous solution

Ion	Salt	IA-PVAL ^a	Non-modified PVAL ^b
Al ³⁺	Al ₂ (SO ₄) ₃ (Alum)	Gelation	No change, Increasing viscosity
Al ³⁺	AlCl ₃	Gelation	No change
Cr ³⁺	(NH ₄)Cr(SO ₄) ₂	Gelation	No change
Cr ⁶⁺	K ₂ CrO ₇	No change	No change
Mn ²⁺	MnCl ₂	Gelation	No change
Mn ⁷⁺	KMnO ₄	Gelation	No change, Increasing viscosity
Ti ³⁺	TiCl ₃	Gelation	No change
Ti ⁴⁺	Na ₂ TiF ₆	No change	No change
Fe ³⁺	Fe ₂ (SO ₄) ₃	Gelation	No change
Fe ²⁺	FeSO ₄	Gelation	No change
Pb ²⁺	Pb(OAc) ₂	Gelation	No change
Cu ²⁺	CuSO ₄	Gelation	No change
Zn ²⁺	ZnSO ₄	Gelation	No change
Co ²⁺	CoCl ₂	Gelation	No change
Mg ²⁺	MgSO ₄	No change	No change
Ca ²⁺	Ca(OH) ₂	No change	No change

^a IA-PVAL: PVAL modified with 5 mol% of sodium itaconate units (Sample 20 in Table 1)

^b Non-modified PVAL: Sample 1 in Table 1

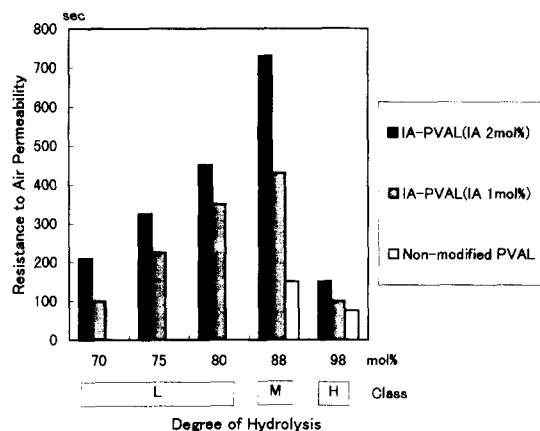

Figure 4 Resistance to air permeability of paper sized with the poly(vinyl alcohol)s modified with sodium itaconate units (IA-PVAL) and with non-modified poly(vinyl alcohol)s. Poly(vinyl alcohol): Polymerization degree: 1750. Pick up amount: 0.83 g m⁻². Resistance to air permeability of pre-sized paper: 30 s

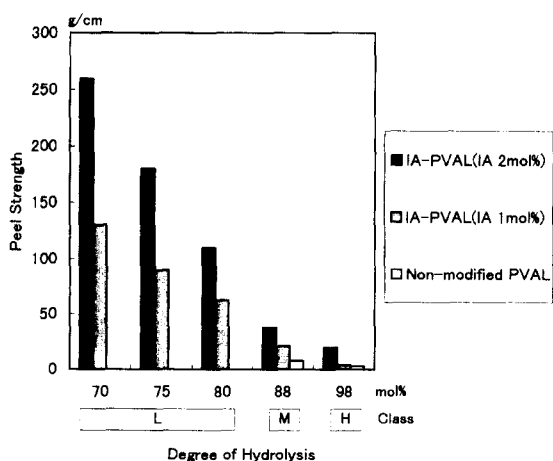

Figure 5 Adhesive strength to poly(ethylene terephthalate) film for the poly(vinyl alcohol)s modified with sodium itaconate units (IA-PVAL) and with non-modified poly(vinyl alcohol)s. Poly(vinyl alcohol): Polymerization degree: 1750. Measurement 20°C, 65% RH

to be exhibited as the result of the reaction between active carboxylate units in PVAL and alum contained in original paper as well as from increasing film-forming property of the modified PVALs.

Textile sizing. Figure 5 shows peel strength of PVAL coated on the surface of poly(ethylene terephthalate) film. Stronger adhesion strength is observed for IA-PVALs with higher modification degree and much lower DH than 80 mol%, a novel area of DH classified as 'L'.

CONCLUSIONS

1. Dibasic acidic monomers like itaconic, fumaric and maleic acid, have been found useful for producing modified PVALs of wider range of DH by copolymerization with VAc followed by alcoholysis without any risk of crosslinking. The PVALs contain active carboxylate groups and show strong reactivity to alum.

2. Among the dibasic acidic monomers, itaconic acid is most significant industrially: maleic acid has difficulty in commercial availability and fumaric acid shows an anomaly of aqueous solution in the PVALs modified thereof.

3. Maleic anhydride, in contrast, shows definitely different results from maleic acid because it generates crosslinking problems in making modified PVALs of lower DH although it can be used for making soluble modified PVALs when highly hydrolysed. The same problem occurs by using other dibasic ester monomers.

4. By using the dibasic carboxylic monomer, itaconic acid in particular, a new group of PVAL having much lower DH, even less than 80 mol% has been able to be used as a novel group of water soluble polymer.

5. Complexity observed in the PVALs modified with various carboxylic monomers can be explained by the chemical-structural point of view: γ -lactone is stable on heating but inactive, δ -lactone makes easily the ring open and crosslinks, γ -sodium hydroxycarboxylates have resistance to making crosslinking but potentially to convert to inactive γ -lactone by the effects of acids, and δ -hydroxycarboxylates have resistance to conversion into δ -lactones.

6. The function of active carboxylates for the novel modified PVALs has been shown in the applications in paper and textile sizing.

7. The expression sometimes written in literature, 'PVAL modified with carboxylic groups' is apt to mislead because the modified PVAL does not contain any 'carboxylic group', -COOH in usual conditions. From the practical point of view considering functionality, 'PVAL modified with carboxylate groups' can be a more proper expression.

ACKNOWLEDGEMENTS

The authors would like to thank Professor T. Okaya for his encouragement and valuable suggestions. They also would like to thank all the members who carried out the development project of the PVALs modified with carboxylic monomers.

REFERENCES AND NOTE

- Nagano, K., Yamane, S. and Toyoshima, K., *Poval* (in Japanese) Kobunshi-Kankoukai, Kyoto, 1970.

2. Imoto, S., *Polyvinyl Acetate Resins* (in Japanese) Nikkan-Kogyo Newspaper Co., Tokyo, 1970.
3. Lindemann, K., in *Encyclopedia of Polymer Science and Technology*, 1st edn. John Wiley & Sons, Inc., New York, 1971, p. 149.
4. Finch, C. A. (ed.), *Polyvinyl Alcohol*, 1st edn. John Wiley & Sons, Ltd., 1973.
5. Nagano, K., Yamane, S. and Toyoshima, K., *Poval*, 2nd edn (in Japanese) Kobunshi-Kankoukai, Kyoto, 1981.
6. Martin, F. L., in *Encyclopedia of Polymer Science and Engineering*, 2nd edn., John Wiley & Sons, Inc., New York, 1989, vol. 17, p. 167.
7. Finch, C. A. (ed.), *Polyvinyl Alcohol*, 2nd edn., John Wiley & Sons Inc., New York, 1992.
8. Moritani, T. and Fujiwara, Y., *Macromolecules*, 1977, **10**, 532.
9. Okaya, T., in ref. 7, p. 4.
10. Sakurada, I., in *Polymer Experiment Series* (in Japanese). Kyoritsu Publishing Co., Tokyo, 1958.
11. Maruhashi, M., in ref. 7, p. 157.
12. Maruhashi, M., in ref. 7, p. 181.
13. Noro, K., in ref. 4, p. 147.
14. Matsumoto, T., *Kobunshi Kagaku*, 1950, **7**, 142.
15. Sakurada, I. and Kawashima, K., *Kobunshi Kagaku*, 1951, **8**, 142.
16. Sakurada, I., Nakajima, A. and Sotobayashi, H., *Kobunshi Kagaku*, 1959, **16**, 363.
17. Kulkarni, N. G., Krishnamurti, N., Chatterjee, P. C. and Sivasamban, M. A., *Makromol. Chem.*, 1970, **139**, 165.
18. Maruhashi, M., Yamamoto, N. and Noro, K., *24th Annual Meeting of Polymer Chem. Japan*, Tokyo, 172, 1A, p. 7.
19. Garrett, T. A. and Park, G. S., *J. Polym. Sci., Part A-1*, 1966, **4**, 2714.
20. Sakaguchi, Y. and Funaya, S., *Kobunshi Kagaku*, 1958, **15**, 677; **15**, 683.
21. Bristol, J. E., US Patent No. 3654247, 1972.
22. Inskip, H. K. and Adelman, R. L., US Patent No. 3689469, 1972.
23. Alfray, T., Lewis C. and Magel, B., *J. Am. Chem. Soc.*, 1949, **71**, 3793.
24. Noro, K. and Takita, H., *Kogyo Kagaku Zasshi*, 1961, **64**, 1302, 1305.
25. Sugai, S. and Woodward, A. E., *J. Polym. Sci., Part A*, 1963, **1**, 2127.
26. Mori, H., Hattori, T., Ikari, K. and Imoto, S., Jap. Patent. Pub. 1969-5331; Br. Pat-1143974, 1966.
27. Amiya, S. and Uetsuki, M., *Macromolecules*, 1982, **15**, 166.
28. Amamiya, K. Jap. Pat. Pub., 1976-38753.
29. Imoto, E. and Horiuchi, H., *Kobunshi Kagaku*, 1951, **8**, 463.
30. Moritani, T., Kajitani, K. and Shiraishi, M., Jap. Pat. Appl. Laid-Open No. 53-91995, 1978.
31. Kajitani, K., Moritani, T., Moritani, K. and Shiraishi, M., Jap. Pat. Appl. Laid-Open No. 53-111189, 1978; US Pat. 4172930, 1979.
32. Moritani, T., Kajitani, K. and Shiraishi, M., Jap. Pat. Appl. Laid-Open No. 56-20698, 1981.
33. Maruyama, H., Moritani, T., Akazawa, T. and Sato, T., *Br. Polym. J.*, 1988, **20**, 345.
34. Okaya, T., in ref. 7, p. 77.
35. Hanna, R. J., *Ind. Eng. Chem.*, 1957, **49**, 208.
36. Bamford, C. H. and Tipper, C. F. H., (Ed) *Chemical Kinetics Vol. 14A, Free-Radical Polymerization*. Elsevier Scientific Publishing Co., Amsterdam, 1976, p. 297.
37. Ham, G. E., (Ed) *Copolymerization*, Interscience Publishers, New York, 1964, p. 29.
38. Bevington, J. C. and Johnson, M., *Eur. Polym. J.*, 1968, **4**, 669.
39. Alfrey, T. and Magel, B., in ref. 36, p. 392.
40. Yamada, M. and Takase, I., *Kobunshi Kagaku*, 1961, **18**, 85.
41. Bevington, J. C., Johnson, M. and Sheen, J. P., *Eur. Polym. J.*, 1971, **7**, 1147.
42. March, J., *Advanced Organic Chemistry*, 3rd edn., John Wiley & Sons, New York, 1985, p. 186.
43. Goodman, I., in *Kirk-Othmer Encyclopedia of Chemical Technology*, Vol. 16. Interscience Publishers, New York, 1968, p. 171.
44. Henniker, J. C., *Infrared Spectrometry of Industrial Polymers*, Academic Press, London, 1967, p. 149.
45. Nowak, R. M. and Rubens, L. C., in *Kirk-Othmer Encyclopedia of Chemical Technology*, Vol. 20. Interscience Publishers, New York, 1969, p. 797.
46. Dmuchovsky, B. and Franz, J. E., in *Kirk-Othmer Encyclopedia of Chemical Technology*, Vol. 12. Interscience Publishers, New York, 1967, p. 824.